

DS-149SF28RQ

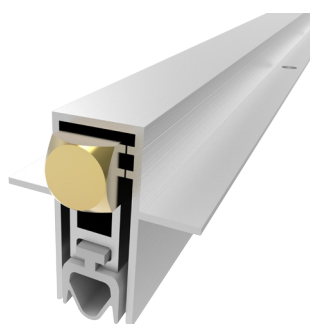

SIZE	MAX SEAL GAP	MAX LENGTH	MIN LENGTH
12x28,5	12	1500	220

FEATURES AND FUNCTIONALITY

Air draughts, light and dust protection	Self levelling drop
Barrier-free access	Steel leaf springs mechanism
Energy saving	Low door opening and closing resistance
Durability up to 1000000 cycles	Suitable for fire doorsets

MATERIALS

Profiles	Aluminium alloy
Gasket	Self-extinguish silicone (working temperatures -40°C/+200°C)
Push button	Brass
Mechanism	Steel

CODE	LENGTH mm	TRIMMING mm	BOX PCS
DS-149SF28RQ400	400	180	36
DS-149SF28RQ600	600	200	36
DS-149SF28RQ800	800	200	36
DS-149SF28RQ1000	1000	200	36
DS-149SF28RQ1200	1200	200	36

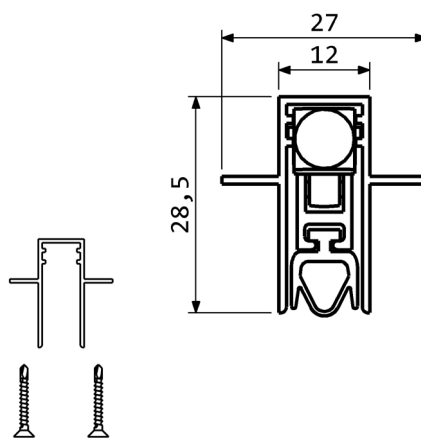

**FIXING ACCESSORIES
(OPTIONALS)**

QUICK AND EASY INSTALLATION

Measure the groove length
Check the product trimming length in the table provided. Cut the seal on the opposite side of the activating plunger. Place the push button on the hinge side. Fix the aluminium case into the groove by screws.

Lift height adjustment: extract the mechanism (hinge side) for about 3 cm and screw (to decrease) or unscrew (to increase) the push button. Reinsert the mechanism up to the locked position.

Find the optimal position opening and closing the door while the seal covers the gap along the entire door length.



PLASTIC COUNTER
PLATE P1830

INOX COUNTER
PLATE P2045KRV

DIMENSIONS IN [mm] - THE MANUFACTURER RESERVES THE RIGHT TO MAKE TECHNICAL CHANGES WITHOUT NOTICE